

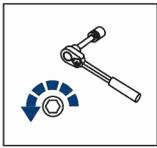

RIVAL UNIVERSAL SNOW BLADE

2444.0100.1.B - black
2444.0100.1.S - gray



EN Regular fasteners
DE Originale montageile

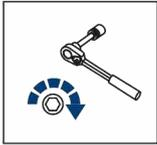

EN Regular fasteners
DE Originale montageile



EN Screw a several turns
DE Für wenigen Umdrehungen befestigen



EN Loosen bolts
DE Bolzen lockern

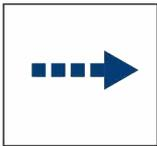

EN Movement Arrow
DE Bewegungsrichtung



EN Location/Position Arrow
DE Anordnung/Positionsrichtung



EN Screw Arrow
DE Drehungsrichtung

Frame
2444.0096.01

 <p>EN Ratchet DE Ratsche</p>	 <p>S - 7; S - 17; S - 10; S - 36 S - 13;</p>	 <p>EN Slotted Screwdriver DE Schlitzschraubendreher</p>
--	--	---

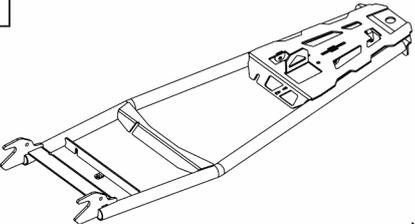
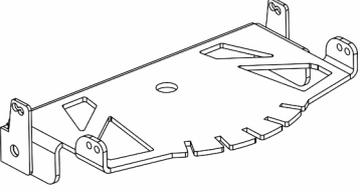
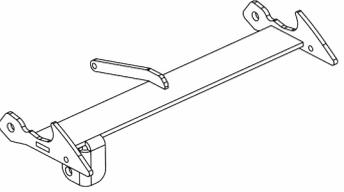
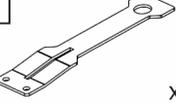
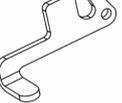
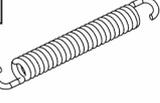
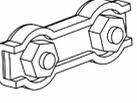
<p>1</p>  <p>x1</p>		<p>2</p>  <p>x1</p>		<p>3</p>  <p>x1</p>	
<p>4</p>  <p>x1</p>	<p>5</p>  <p>x1</p>	<p>6</p>  <p>x1</p>	<p>7</p>  <p>x2</p>	<p>8</p>  <p>x2</p>	<p>9</p>  <p>x1</p>
<p>10</p>  <p>M6x40 x1</p>	<p>11</p>  <p>M8x25 x5</p>	<p>12</p>  <p>M8x60 x1</p>	<p>13</p>  <p>M10x35 x1</p>	<p>14</p>  <p>M24x60 x1</p>	<p>15</p>  <p>ø6 x2</p>
<p>16</p>  <p>ø8 x12</p>	<p>17</p>  <p>ø10 x2</p>	<p>18</p>  <p>ø24 x2</p>	<p>19</p>  <p>ø24 x1</p>	<p>20</p>  <p>M6 x1</p>	<p>21</p>  <p>M8 x6</p>
<p>22</p>  <p>M10 x1</p>	<p>23</p>  <p>M24 x1</p>				

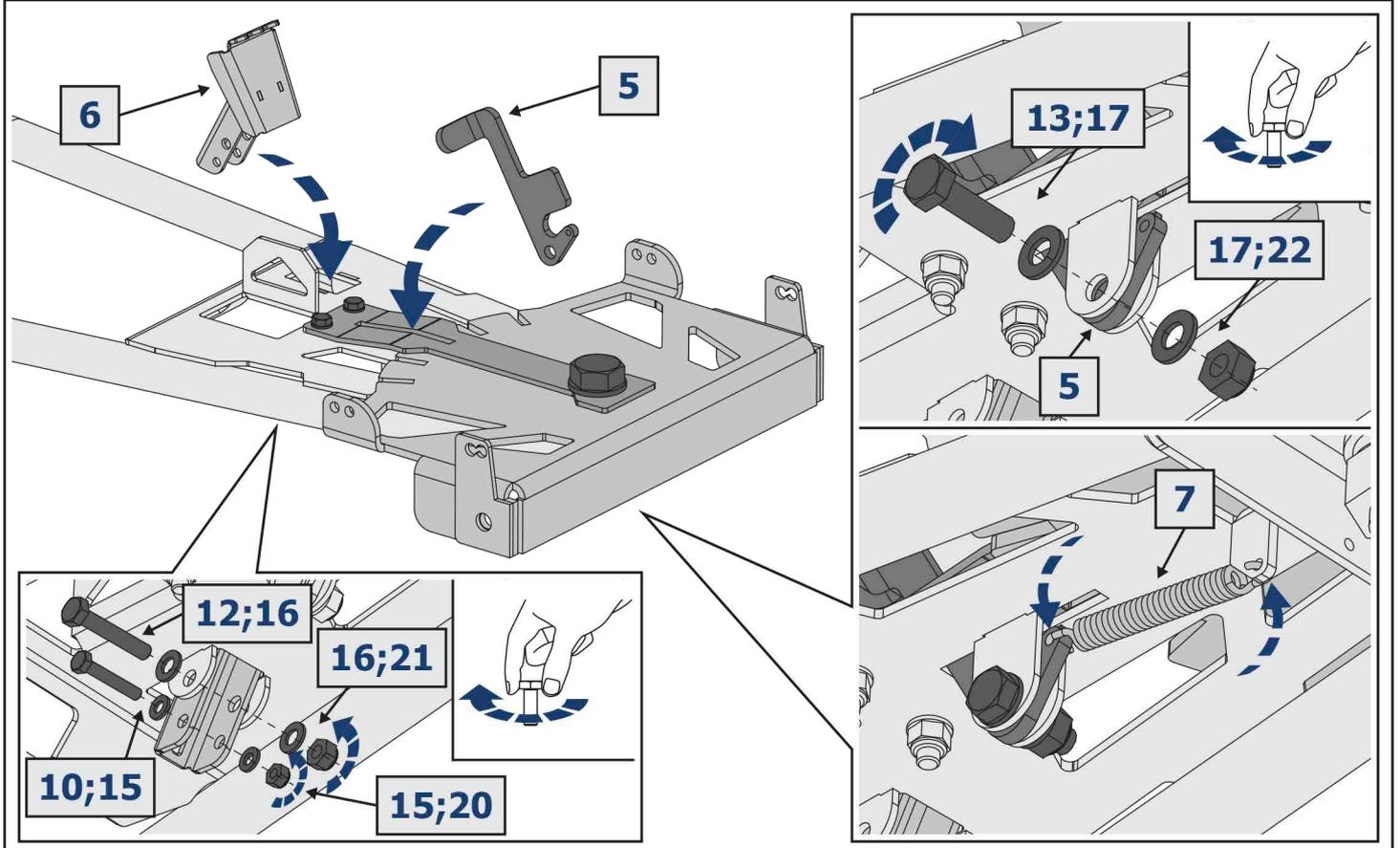
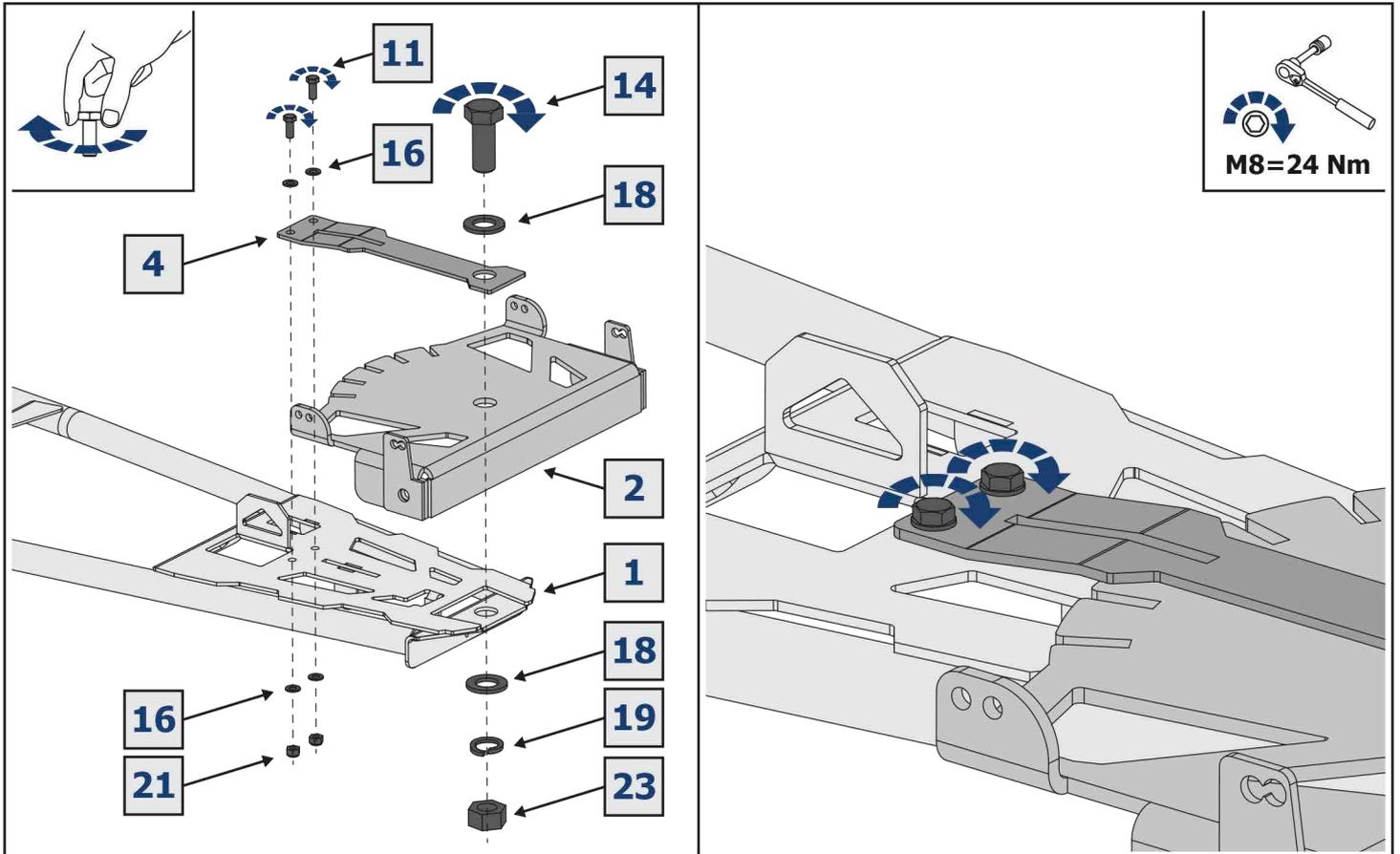

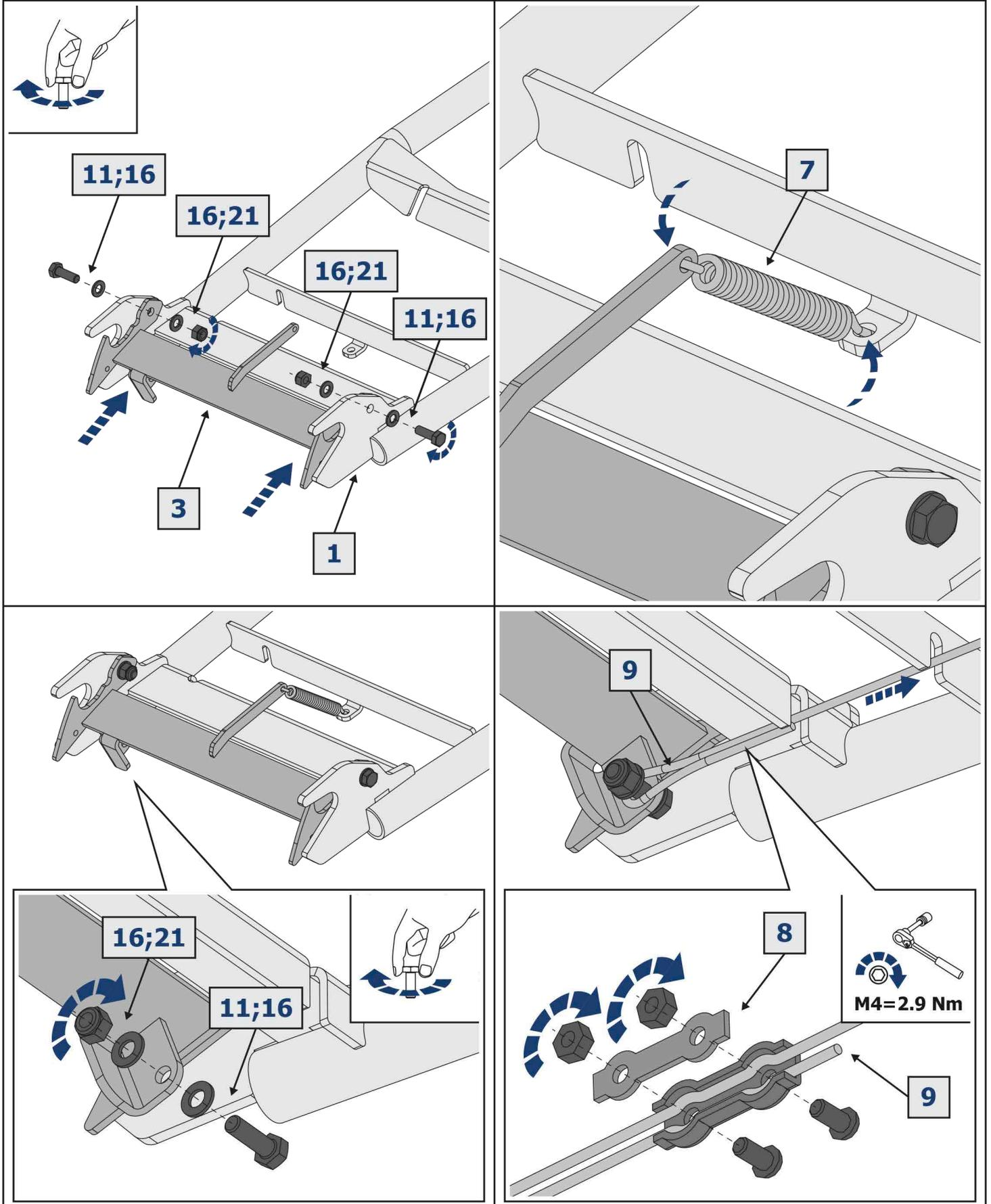

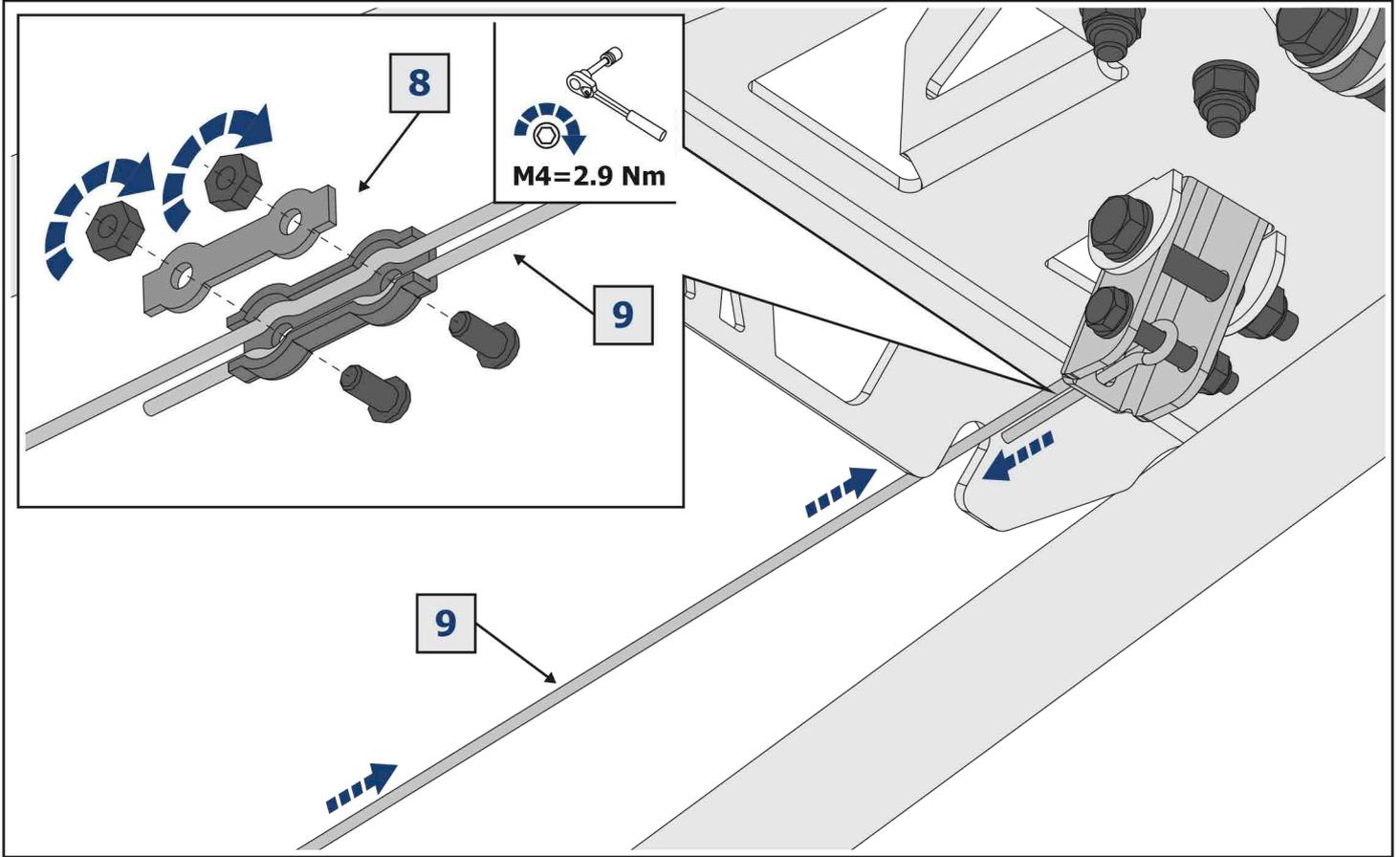

Bucket

2444.0101.01 - 150 mm.

2444.0101.02 - 137 mm.

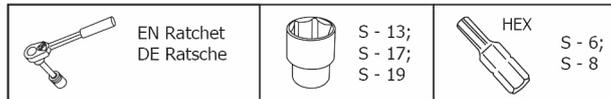

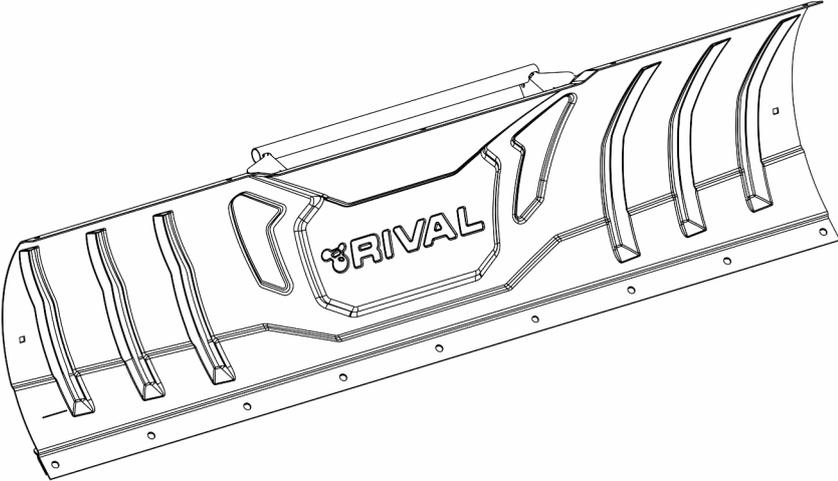
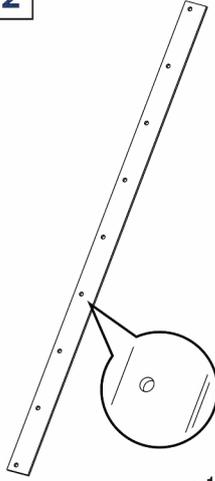
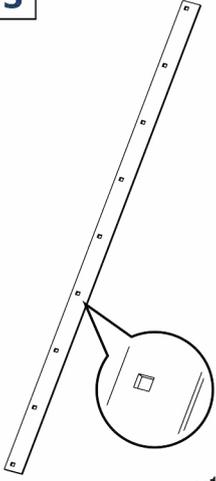
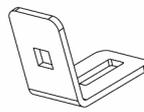
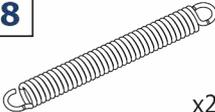
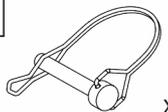
1 				2 		3 					
4 		5 		6 		7 		8 		9 	
10 		11 		12 		13 		14 		15 	
16 		17 		18 		19 		20 			
M8x20 x1		M8x20 x4		M10x20 x2		M10x30 x9		M12x40 x2		ø8 x6	
ø10 x11		ø12 x4		M8 x5		M10 x11		M12 x2			

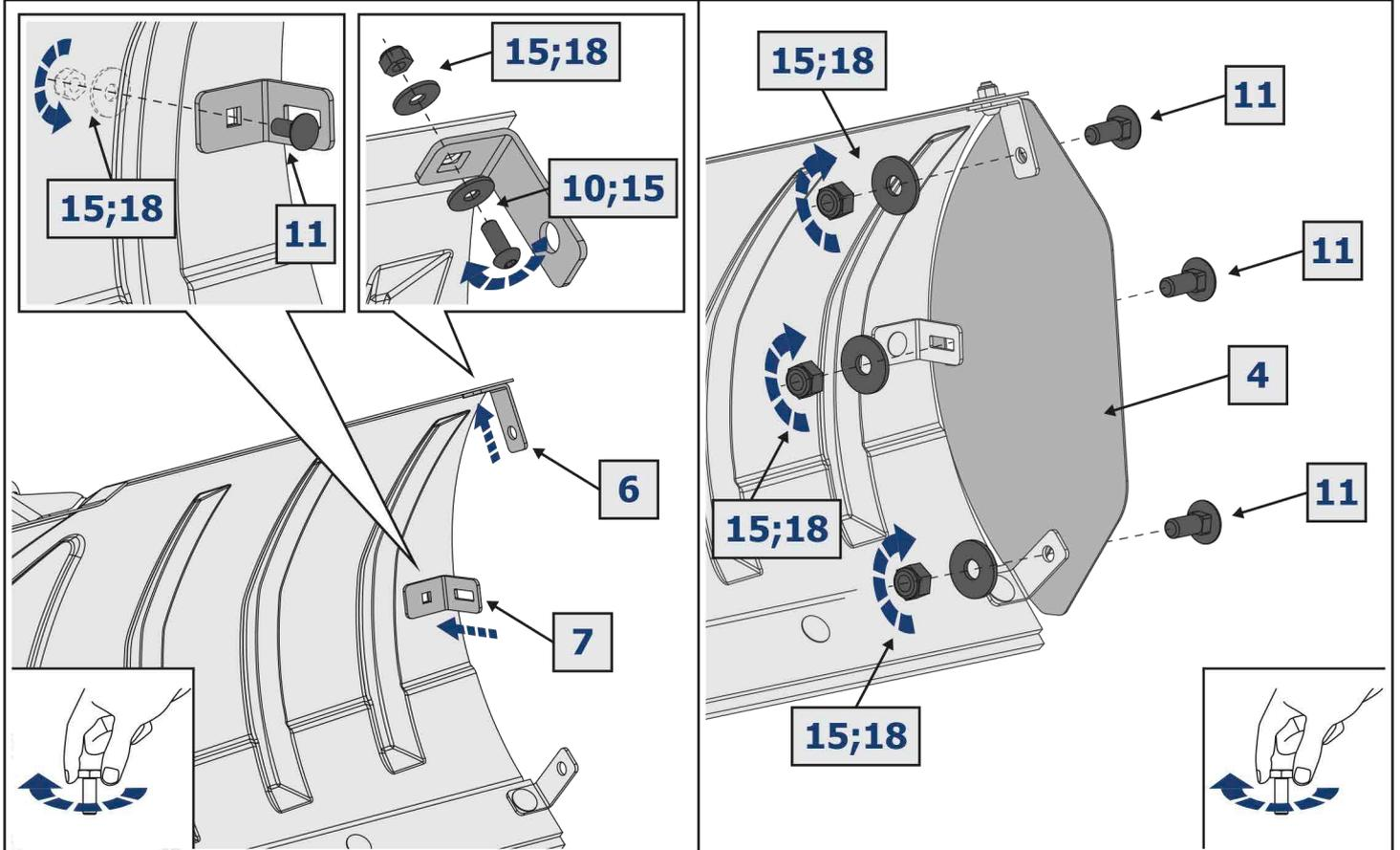
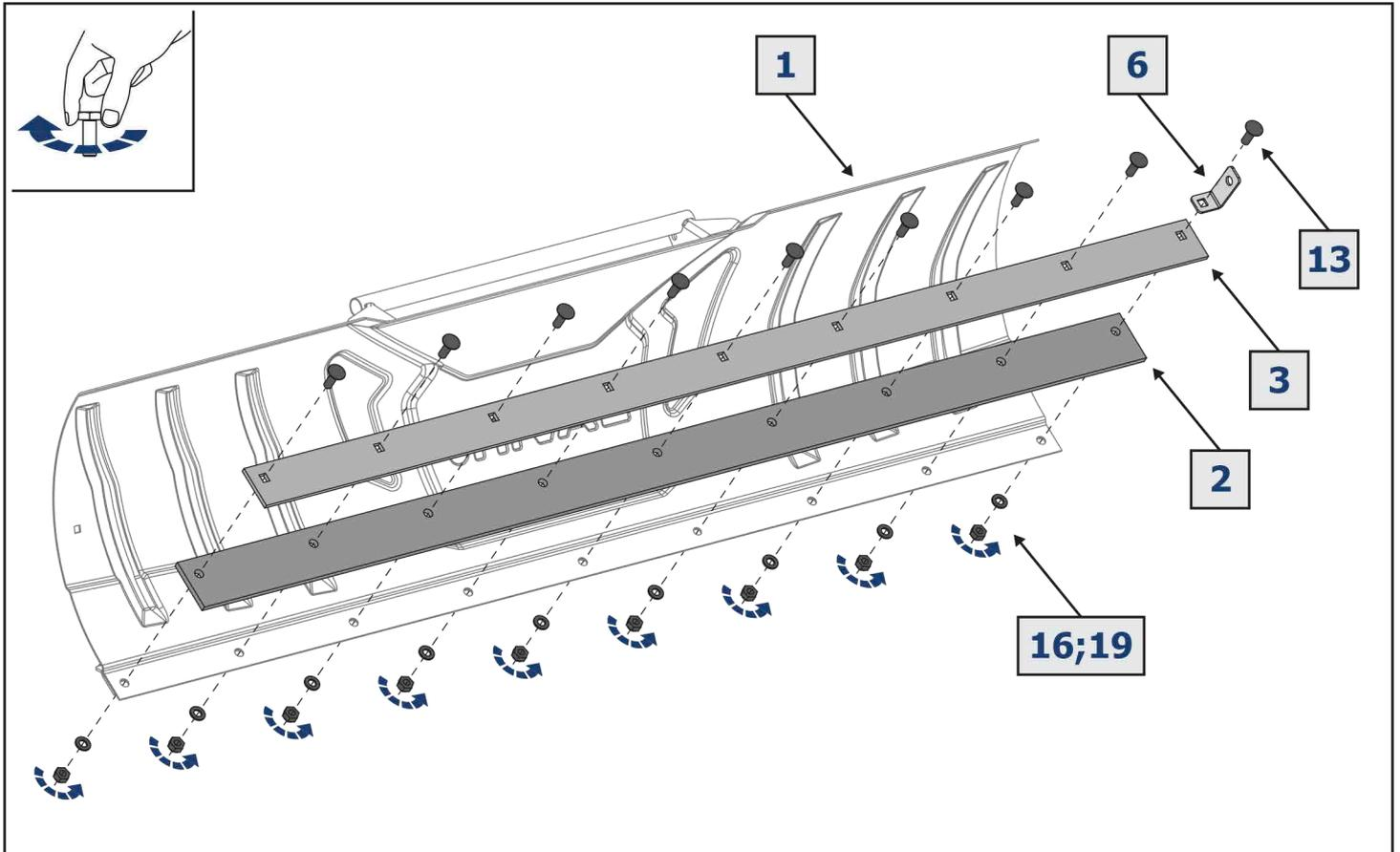

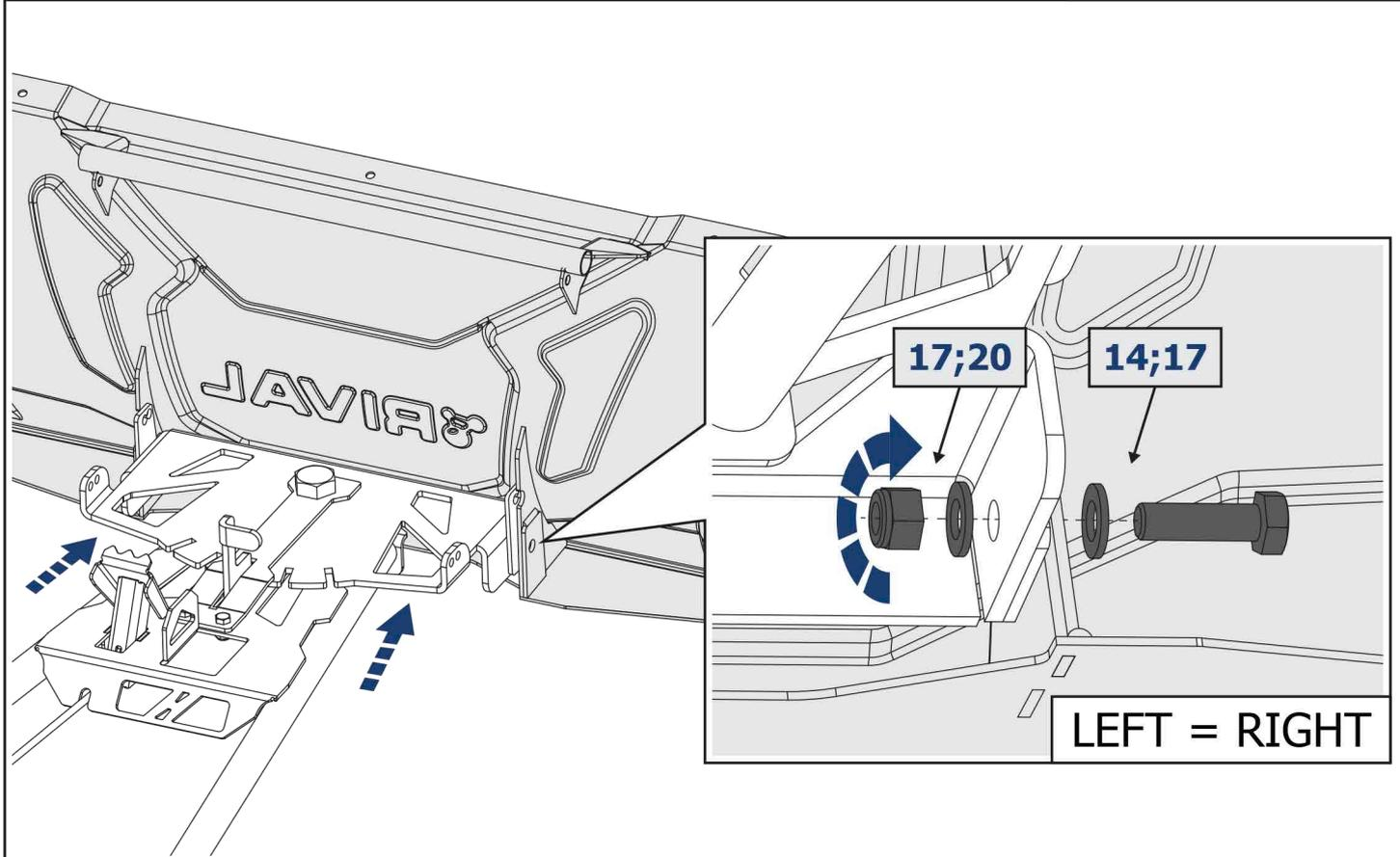
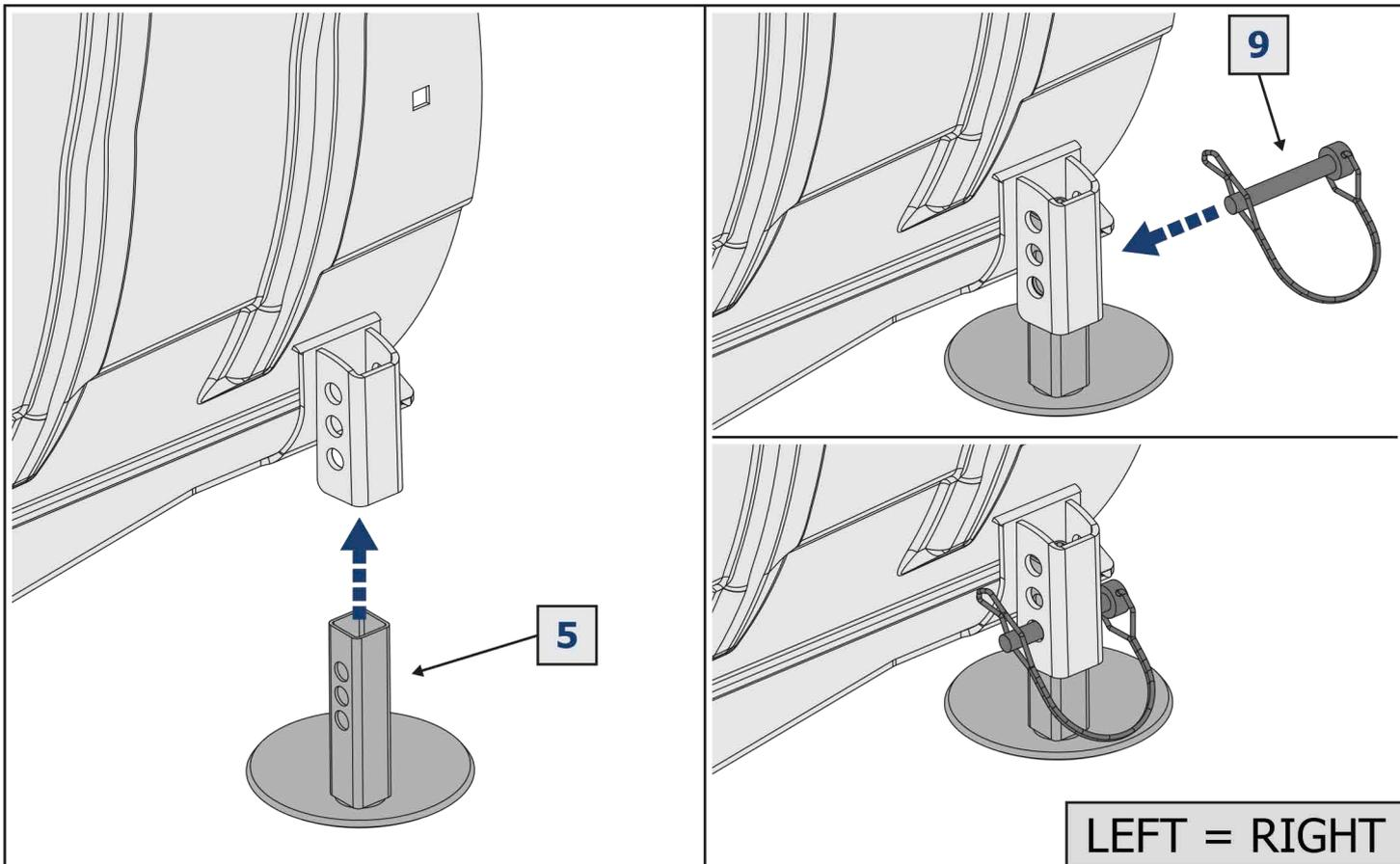

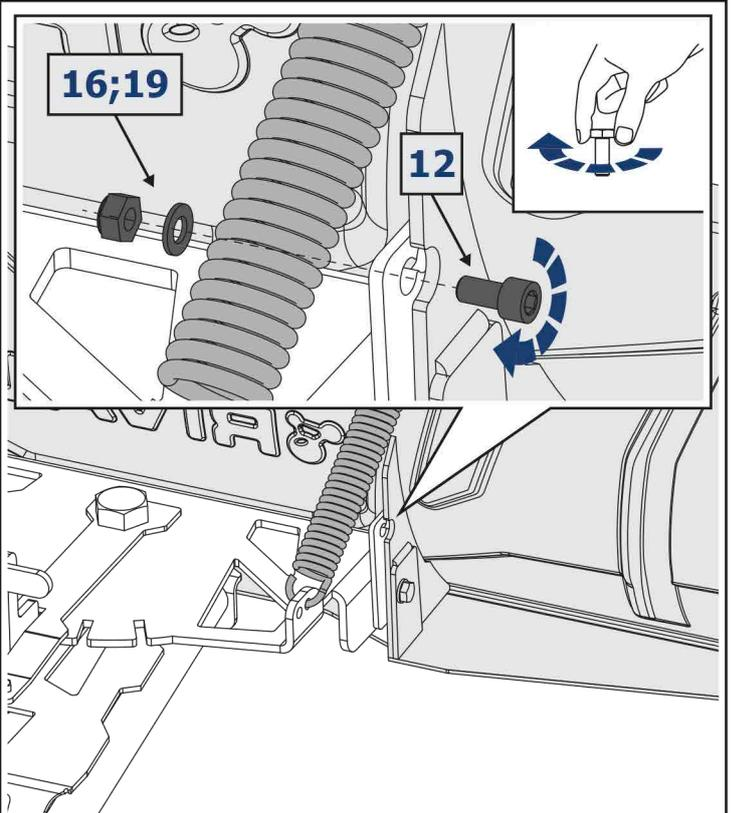
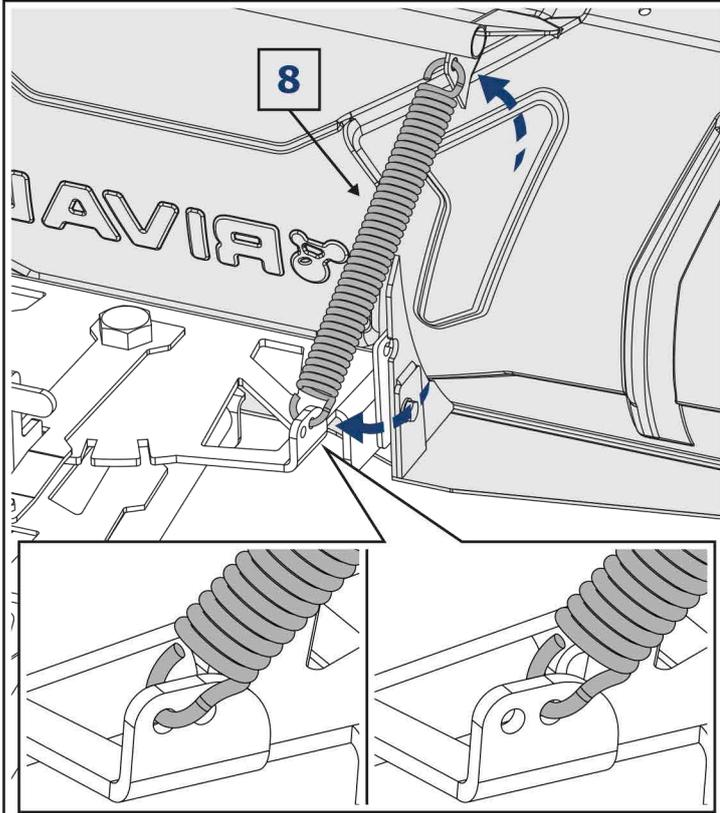

LEFT = RIGHT

LEFT = RIGHT

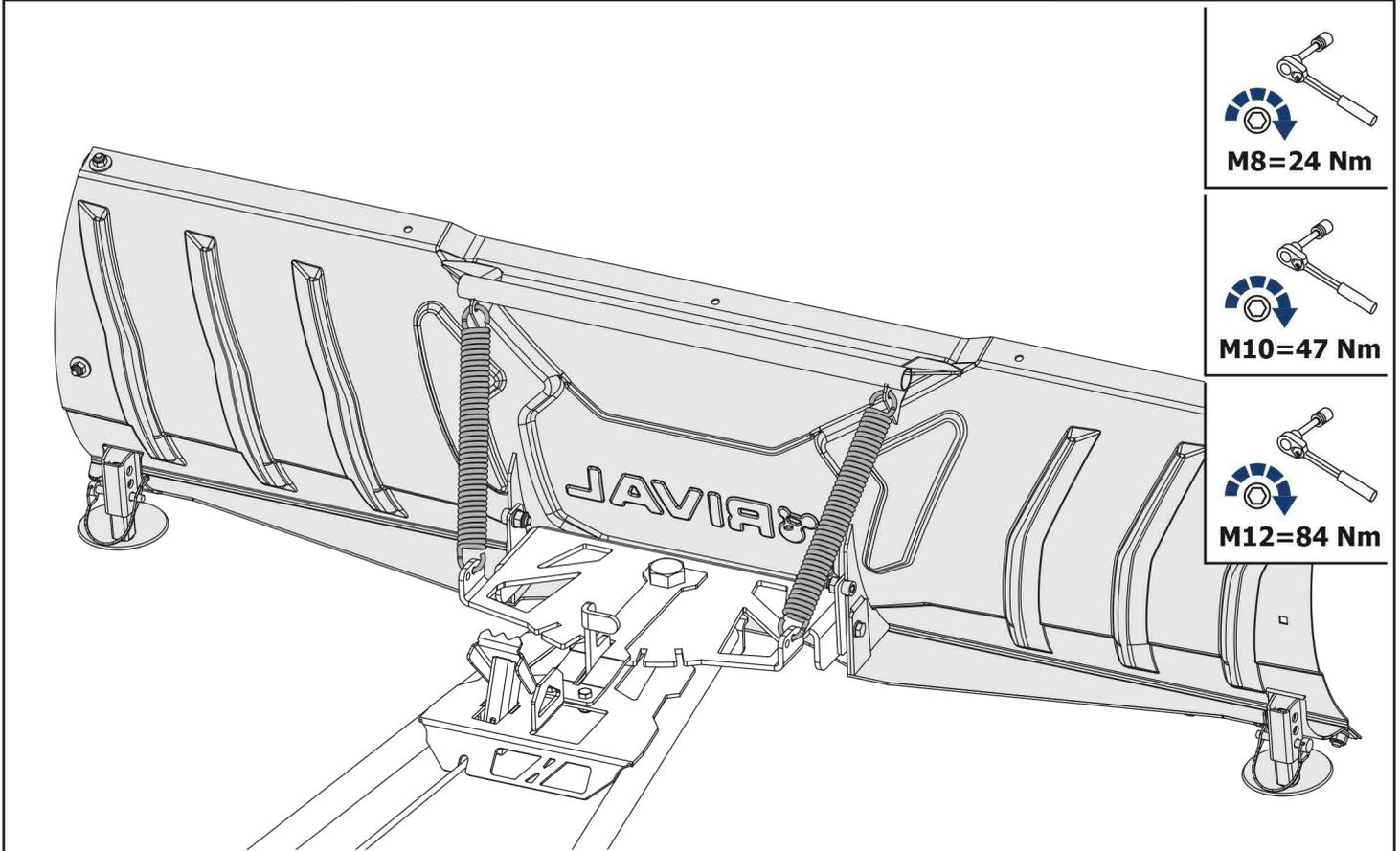

Universal snow blade mounting pad

2444.0102.1



1

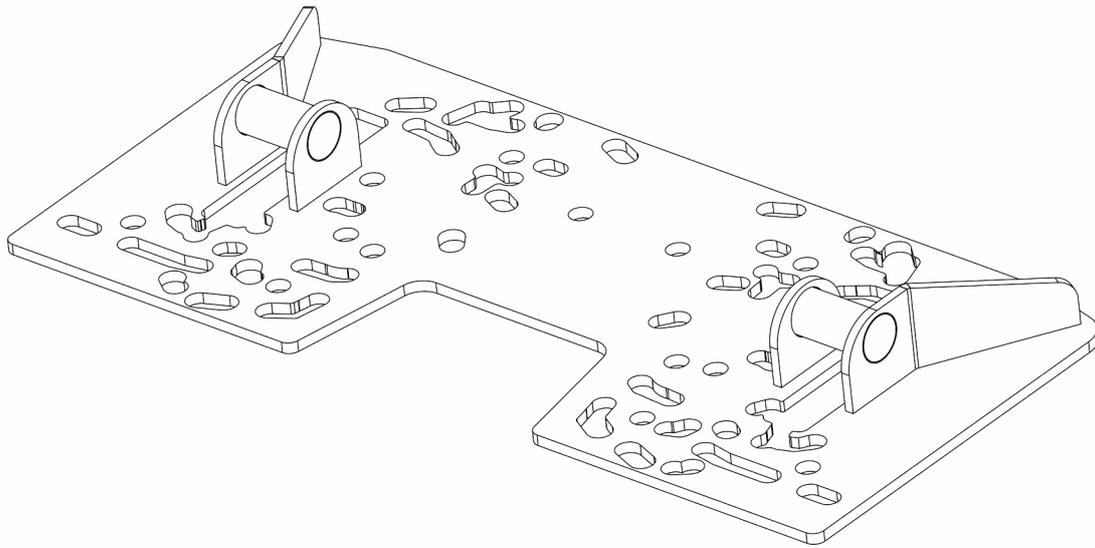

x1

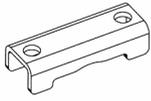
<p>2</p>  <p>x4</p>	<p>3</p>  <p>x4</p>	<p>4</p>  <p>M8x80</p> <p>x8</p>	<p>5</p>  <p>ø8</p> <p>x4</p>	<p>6</p>  <p>ø8</p> <p>x8</p>	<p>7</p>  <p>M8</p> <p>x4</p>
---	---	--	---	---	---

RM 500, 500-2, 650-2

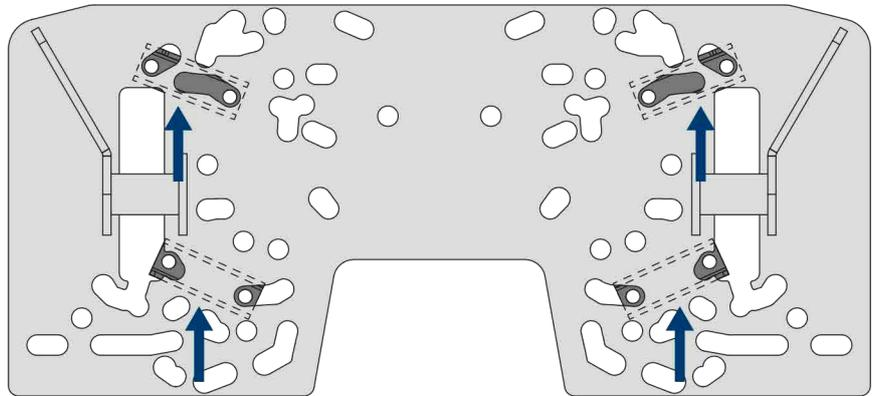
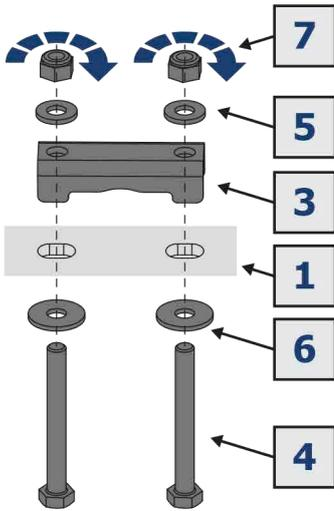

CFMOTO CFORCE 400/450/520

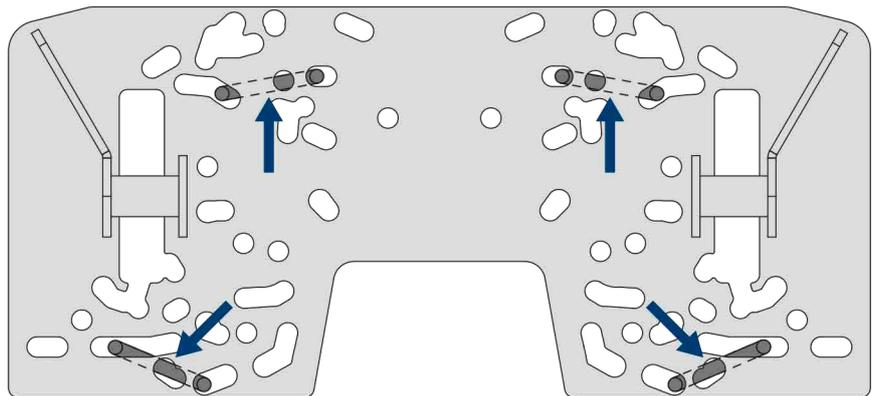
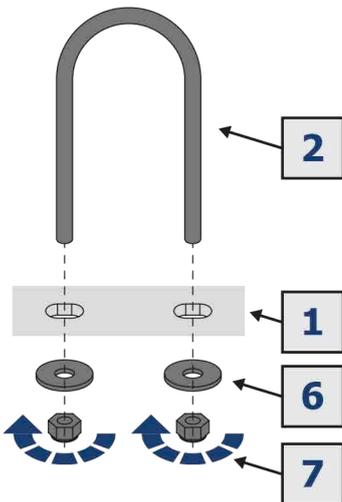

CFMOTO CFORCE 550

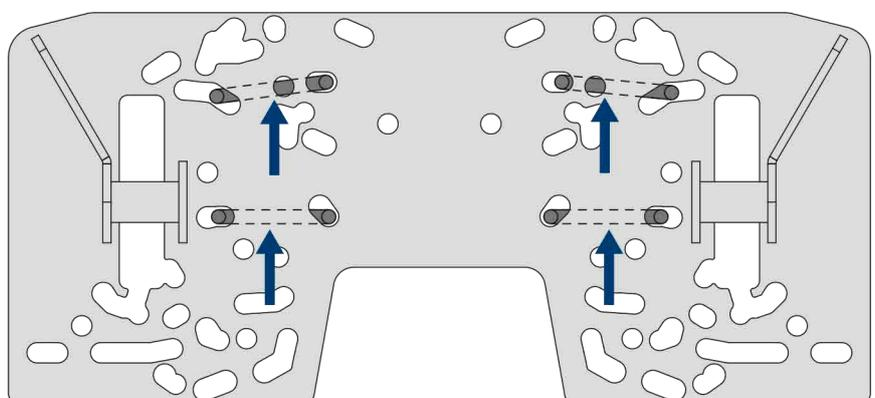
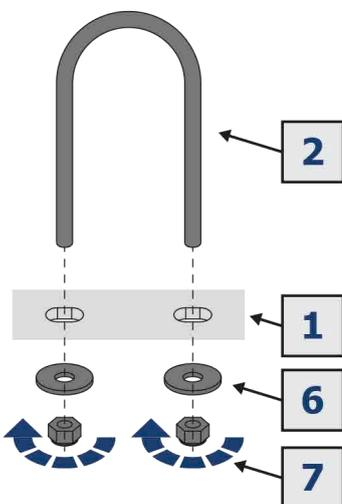

CFMOTO CFORCE 500/600

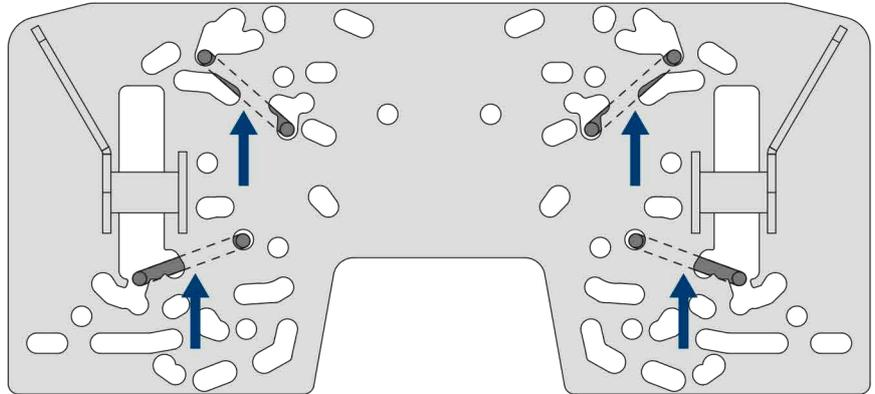
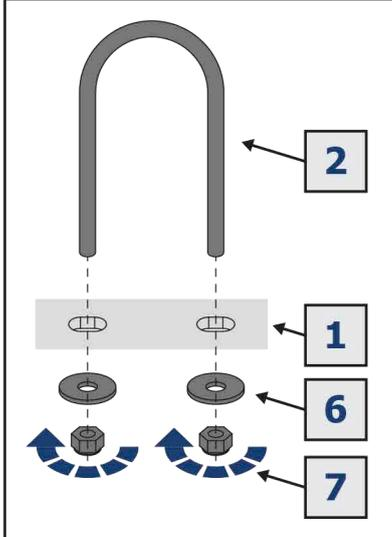

CFMOTO CFORCE 800/820

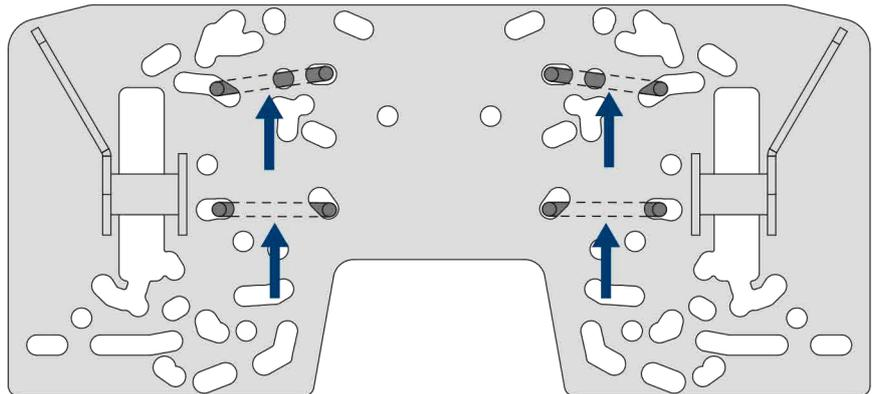
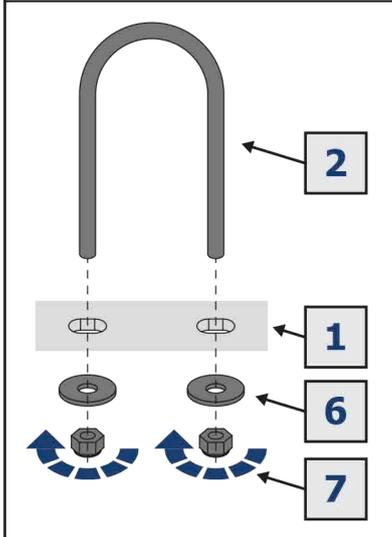

CFMOTO CFORCE 850

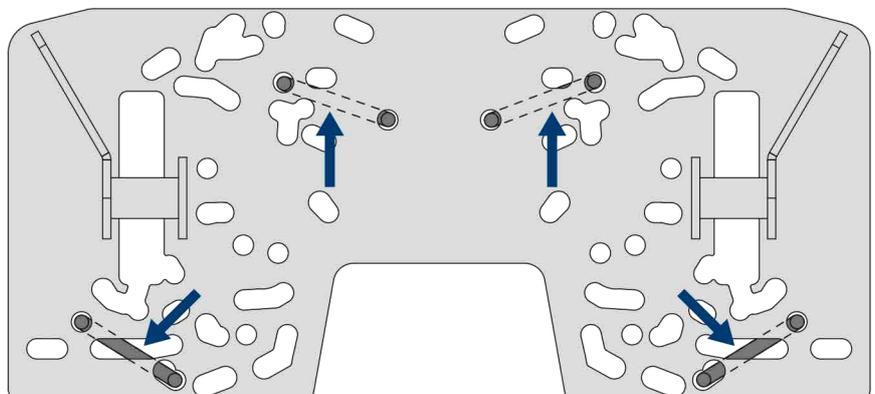
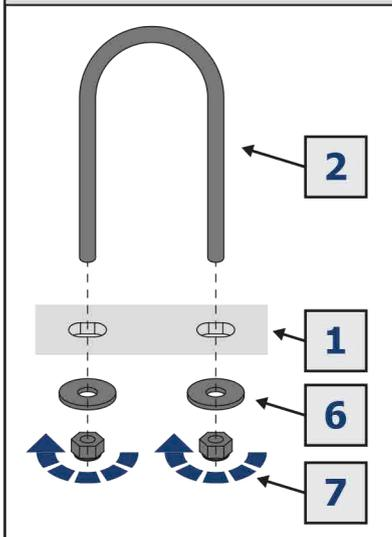

Honda TRX 420/500

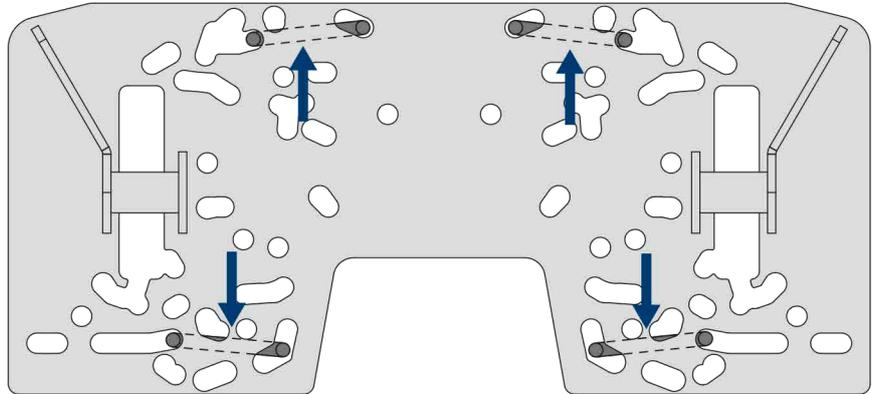
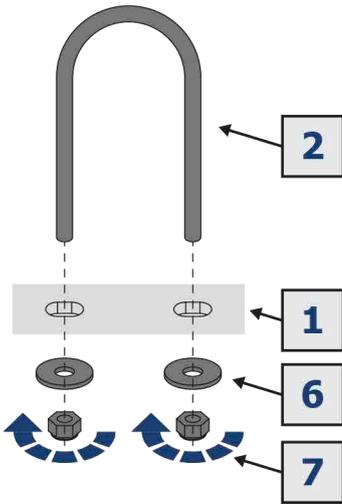

Honda TRX 680

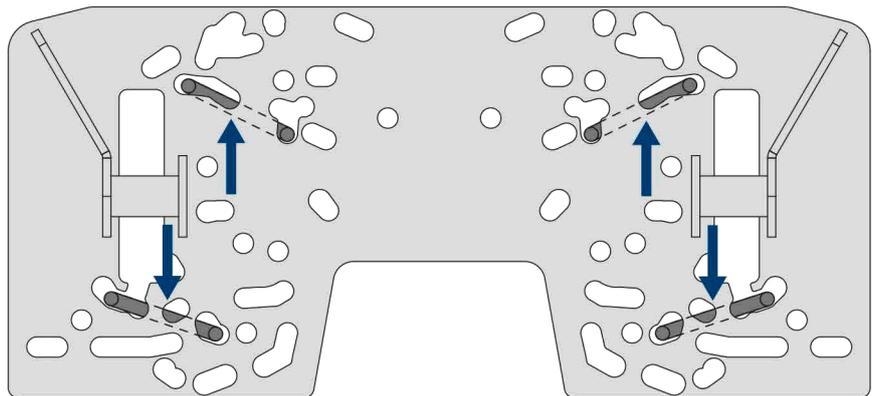
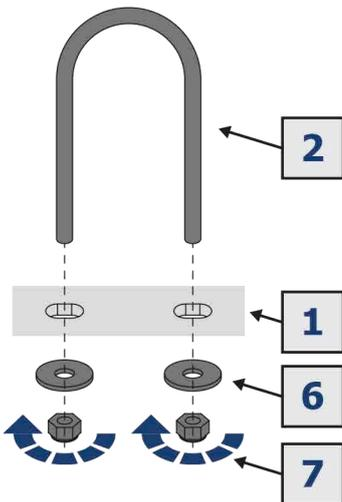

Kawasaki KVF 750

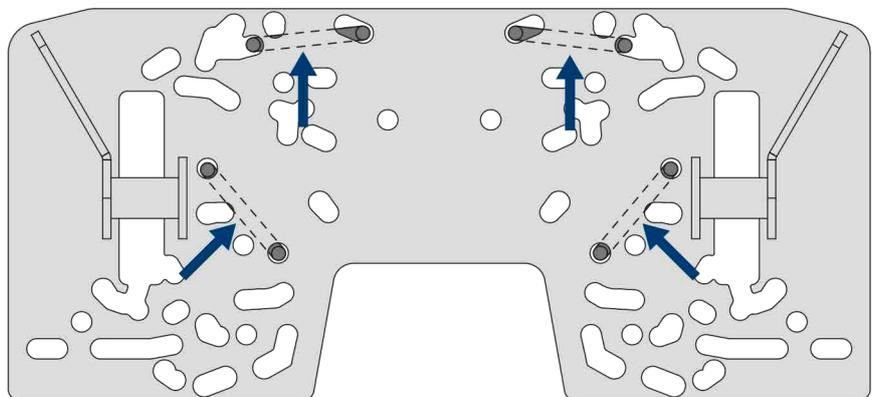
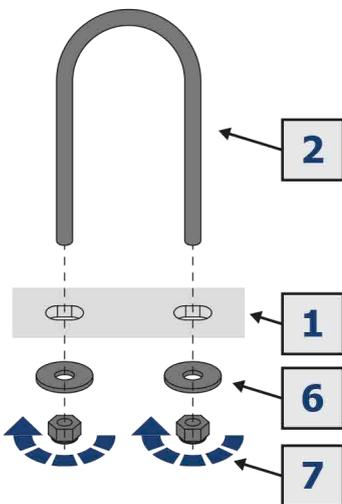

Polaris Scrambler 850/ 1000

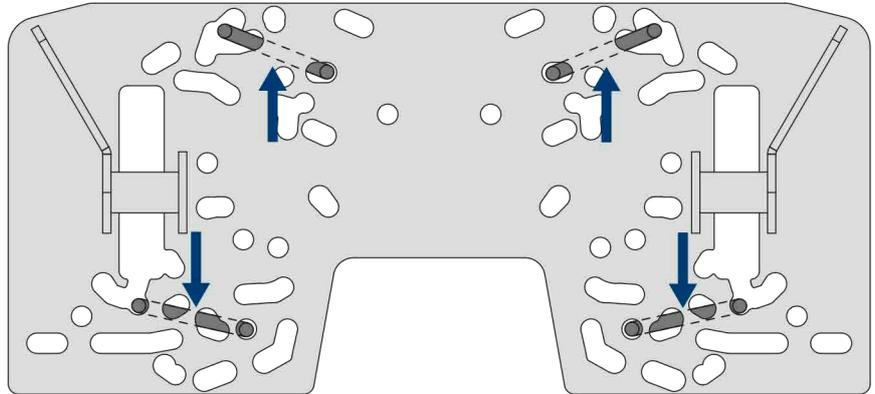
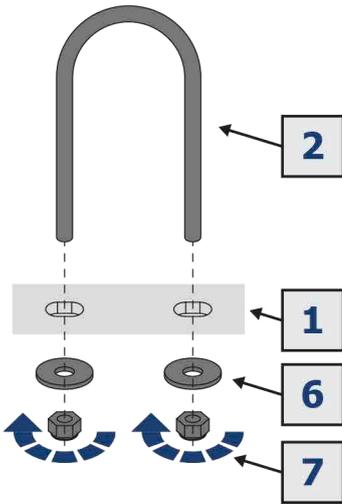

Polaris Sportsman 850

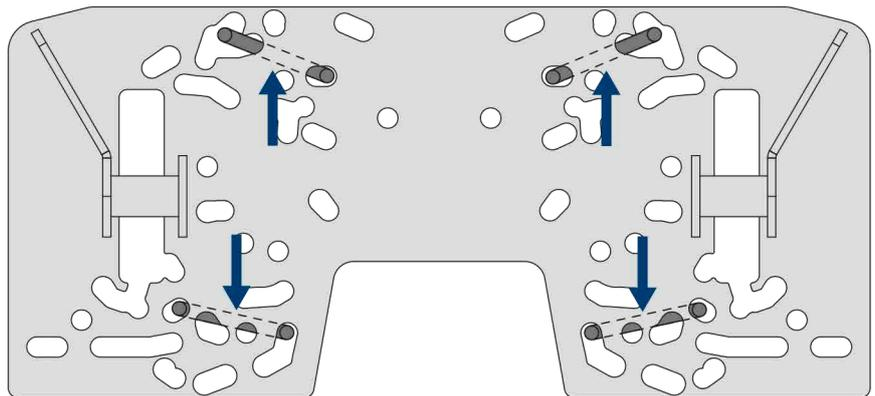
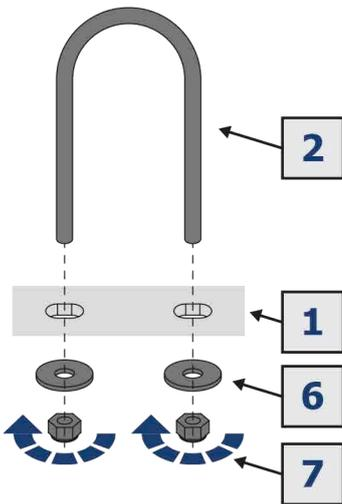

Yamaha Grizzly 350/450

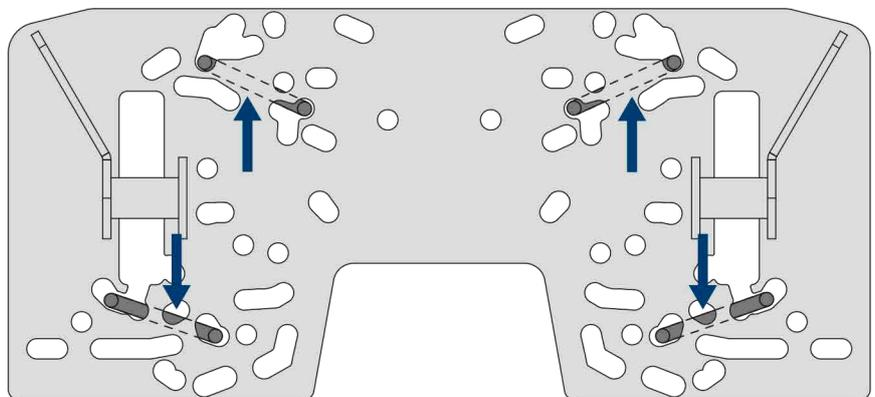
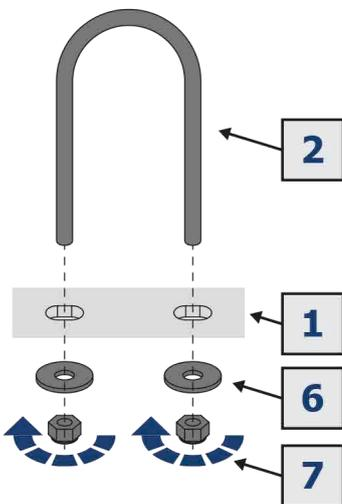

Yamaha Grizzly 550/700; Kodiak 700

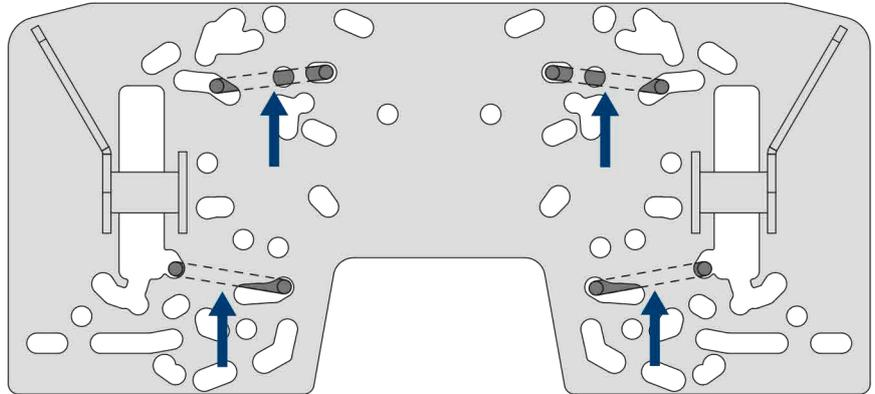
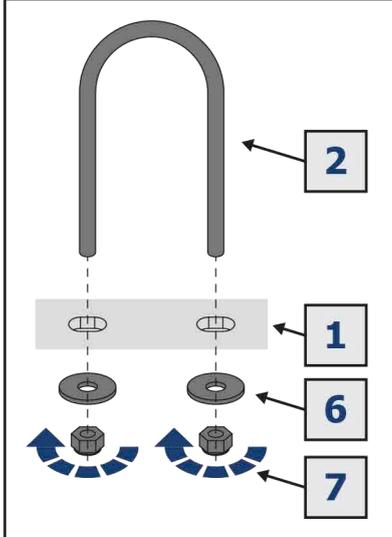

Stels Leopard 600/650

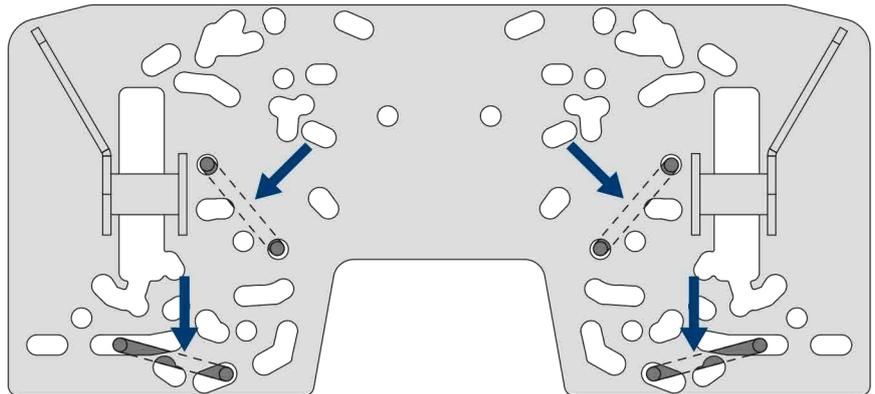
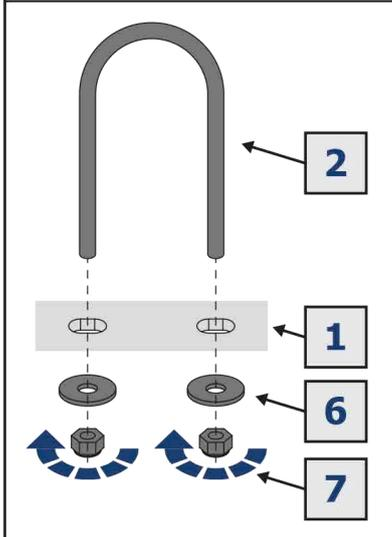

Stels Guepard 650/800/850

